

XL246-A

Securaplane's XL246-A is an Emergency Battery System providing 6 amps of power at 18 to 24VDC. This unit is currently available and PMA'd on Canadair Challenger 601-3A/3R, Falcon 50, Gulfstream G-III, MD-80, and soon on MD-11 as well as many other aircraft types. The XL246-A is a direct replacement for the ACME AMPS 2000 on all these aircraft types.

**Direct Replacement for the
ACME AMPS 2000**

Advantages

- Built-In Test Equipment
- No Deep Cycling
- No "Memory" Characteristics
- Inexpensive Battery Replacement
- Full 3 Year Warranty on Batteries
- Full 5 Year Warranty on Electronics
- **No Need to Remove for Capacity Check**

Applications

- IRS/INS Back-up Power
- Avionics Back-up Power
- Emergency Lighting
- Communications Back-up Power

Batteries

Sealed Lead Acid batteries (Dry Cells). 24V 6AH at the one hour discharge rate. Provides long life, six month storage capability, and requires no scheduled maintenance.

Battery Charger

Precision charges battery from aircraft 28 VDC power bus. Unit has the capability to operate in bulk or temperature compensated constant voltage charge modes. Contains overheat protection, built-in test and overload protection. Battery will reach 80-90% full charge from a fully discharged state in one hour.

Battery Test

Battery test function, places a known load on the battery and measures the terminal voltage on load over 60°F. Indicates low, mid or full battery level. **No need to remove batteries to perform capacity check.**

Diagnostics

Continuous BIT monitors charger/control logic, battery cell voltage and battery heater circuit. Front panel mounted BITE software exercises BITE circuits. Works in conjunction with battery level test to validate capacity check.

Environmental Control

Thermal blanket automatically controls battery ambient below 60°F to optimize battery performance.

Solid State Switching

All switching is performed through low loss solid state circuitry.



XL246-A

XL246-A Emergency Battery System - Block Diagram
P/N 100-0202-01 (P/N 100-0202-02 if 10 amp required).

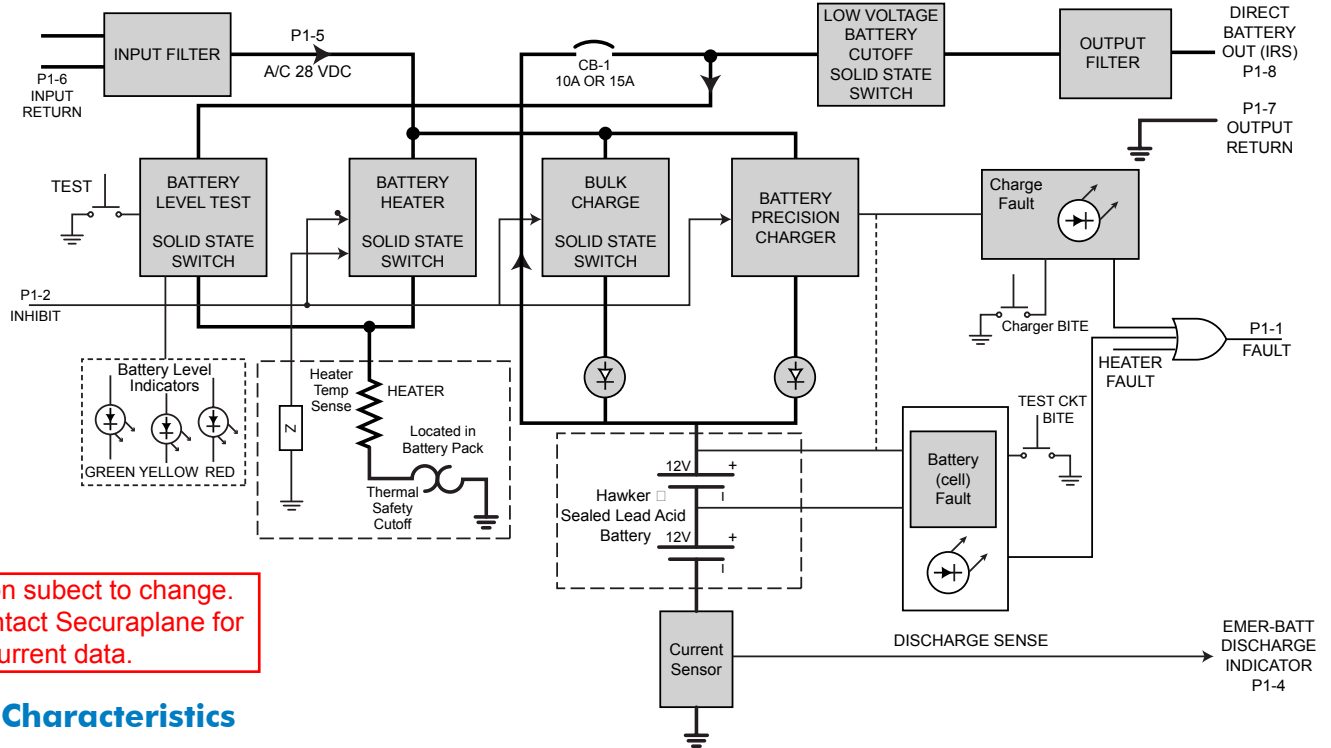

Information subject to change.
Please contact Securaplane for current data.

Physical Characteristics

- Size:** ARINC 404, 1/2 ATR short.
(7.7 x 4.855 x 12.82 inches) max
- Box Connector:**
ARINC 404 DPXBMA-D8P-34B Cannon or equivalent
- Qual:** DO-160 -55 to + 71° C (55,000 ft)

- Weight:** 18.6 lbs. (max)
- Mounting:** 1/2 ATR short tray
- Cooling:** Convection (No forced air)

P/N 100-0202-02 10 amp unit is available for installations where existing wiring can only handle 10 amps.

Functional Characteristics

Signal Outputs		Power Characteristics at 60° F or Greater
No charge (fault) output (sinks 0.5A max)	Provided when there is a failure of charger, heater or battery. If there is a charger fault the battery energy will be still available for emergencies.	
Satt on output (sources 160mA max)	Indicates that the battery is feeding the external loads.	
Signal Inputs		
Charger inhibit (+28VDC)	Inhibits charge and heater functions. Enables A/C systems to check battery voltage.	Input Power 20-35 VDC (28 VDC nominal). 10 Amps maximum Output Power 18-24 VDC 200W for 45 minutes (2.9 ohm load) 6A for one hour (min) 15A max (-01 version) 10A max (-02 version) Battery Pack 24 VDC. 6AH (at 1 hr rate) Sealed lead acid Dry) Battery Heater 28 VDC (from A/C Bus) 2.8A when "on" below 60° F