



"Pure Lead" Sealed Lead Acid Main Ship Battery

43 Ah



Now available for 747-100, 747-200, 747-300, and 747-SP

Hawker sealed aircraft batteries have been designed for high power, long life, and low maintenance, thereby meeting a wide variety of civil and military requirements. Hawker's unique pure lead grids and high percentage (99.5%) recombination technology ensure long shelf life and fast recharge capabilities.

All of Hawker's aviation battery products are classified as non-hazardous and unrestricted for land, sea, or air transportation when correctly packed. This battery needs no regular maintenance, has no memory effect, and doesn't suffer from fading. Depending on operation and use, the battery can provide up to a 5 year life before reblocking.

Advantages:

- **Hot and cold performance far exceeding that of any other aviation battery.**
 - Cold — 50% more cranking amps of any other equivalent-rated aviation battery at -40° C/F
 - Hot — Qualified to operate at temperatures up to +75°C, with expected operating life greater than 3 years at +30°C.

- **True no-maintenance battery.**

- **Recovers From Deep Discharge**

The main current carrying structures inside a Hawker battery are constructed of pure lead-tin plates. Because of the purity of the lead, Hawker SLA batteries do not exhibit typical characteristics of Lead-Calcium and Lead-Antimony batteries. Hawker SLA batteries have exceptional charge retention and superb deep discharge recovery.

- **High Capacity**

Hawker's unique manufacturing process produces plates that are very thin – .7mm thick as opposed to the 2-4mm thick plates common to most lead-calcium SLA batteries. Thinner plates mean each cell can contain more plates without increasing the overall size or weight of the battery. More plates means the Hawker battery contains a much higher surface area contact between the positive and negative active materials, resulting in a very high discharge rate and faster recharge capability.

- **Battery block replacement** at significantly less than the list price of a new battery.
- **Shipped fully charged and ready to install**
- **Steel Case**
Epoxy coated steel case

Other Certifications:

Hawker 43 Ah series batteries are STC'd and PMA'd for installation on these aircraft:

- Beechjet 400, 400A, 400T
- Boeing 747-100, -200, -300, -SP
- Cessna Citation I, II, V, Bravo, Ultra, Encore
- Bombardier CRJ-100, -200, -700, -900
- DHC-8-100, -200, -300
- EMB-120
- Falcon 2000, 2000EX
- Gulfstream III(AC), IV
- Hawker 400XP
- King Air 100, 200, 300, 90 Series
- Challenger 300 (STC Project open)



Hawker 43 Ah

Part Number 9750W0370-10





"Pure Lead" Sealed Lead Acid Main Ship Battery

4.3 Ah

SPECIFICATIONS:

Part Number:

9750W0370-10

Size:

12.10" x 11.02" x 10.22"

DC Connector (J1):

MS18093/MS3509

Qual:

DO-160C

Weight:

91 lb. (41.28 kg)

Nominal Voltage:

24V

Nominal Capacity:

43Ah

Transportation:

Non-hazardous and unrestricted when securely packed and protected against short circuit.

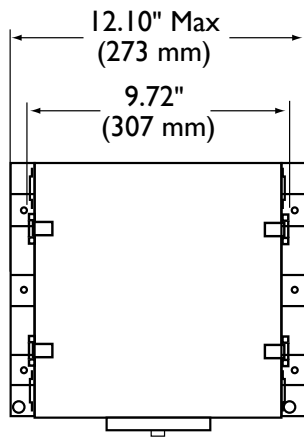

Information subject to change.
Please contact Securaplane for
current data.

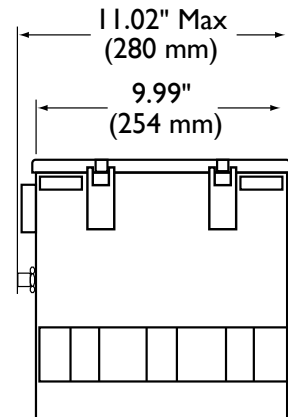
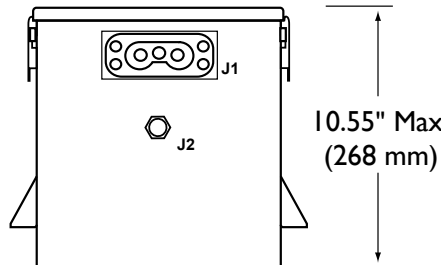

PERFORMANCE CURVES:

STORAGE OF UNCOMMISSIONED PRODUCT

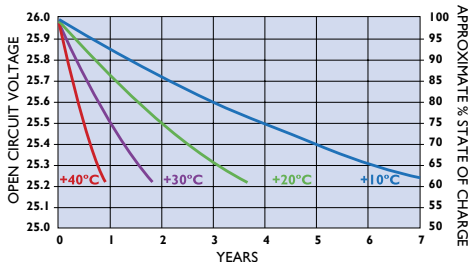

CHARGE ACCEPTANCE BS 6G 205 Clause 8.11

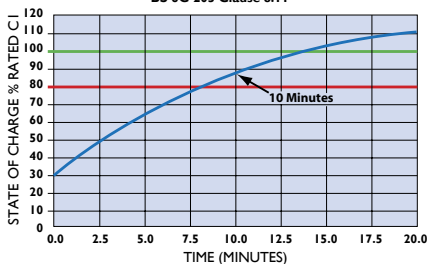

POWER RATING

Testing of Group B sample to Batspec 210
clause of 3.9 and IEC 952-1 clause 6
Test Reference PDTR 1817 - June 1998

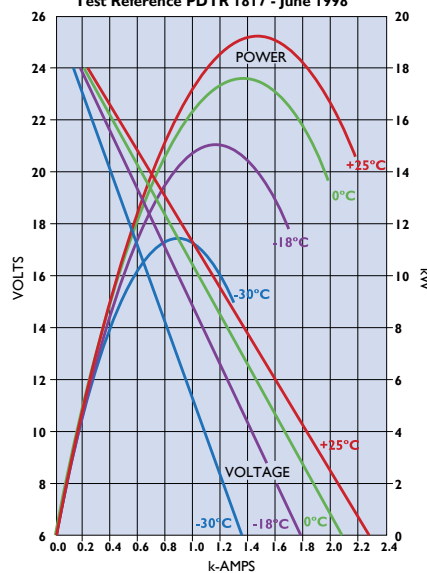

EASY REBLOCKING:



Internal monoblocks can be replaced at significant savings over the replacement cost of the battery.